

## Problem Set #1 Basic concepts – complex algebra and three-phase balanced circuits

### 1-1

Evaluate the following expressions in polar form:

a)  $a-1$

b)  $1-a^2+a$

c)  $a^2+a+j$

d)  $ja+a^2$

### 1-2

Three identical impedances of  $10\angle-15^\circ \Omega$  are Y-connected to balanced three-phase line voltages

of 208 V. Specify all the line and phase voltages and the currents as phasors in polar form with  $V_{ca}$  as reference for a phase sequence of  $abc$ .

### 1-3

In a balanced three-phase system the Y-connected impedances are  $10\angle30^\circ \Omega$ . If  $V_{bc} = 416\angle90^\circ \text{ V}$ ,

specify  $I_{cn}$  in polar form.

### 1-4

Determine the current drawn from a three-phase 440-V line by a three-phase 15-hp motor operating at full load, 90% efficiency, and 80% power-factor lagging. Find the values of P and Q drawn from the line.

### 1-5

If the impedance of each of the three lines connecting the motor of Problem 4 (or Prob 1.16) to a bus is  $0.3+j1.0 \Omega$ , find the line-to-line voltage at the bus which supplies 440V at the motor.

### 1-6

Draw the single-phase equivalent circuit for the motor (an emf in series with inductive reactance labeled  $Z_m$ ) and its connection to the voltage supply described in Prob 1-4 and 1-5. Show on the diagram the per-unit values of the line impedance and the voltage at the motor terminals on a

base of 20 kVA, 440V. Then using per-unit values, find the supply voltage in per unit and convert the per-unit value of the supply voltage to volts.

**1-7**

Consider a 3- $\phi$  distribution feeder as shown below:

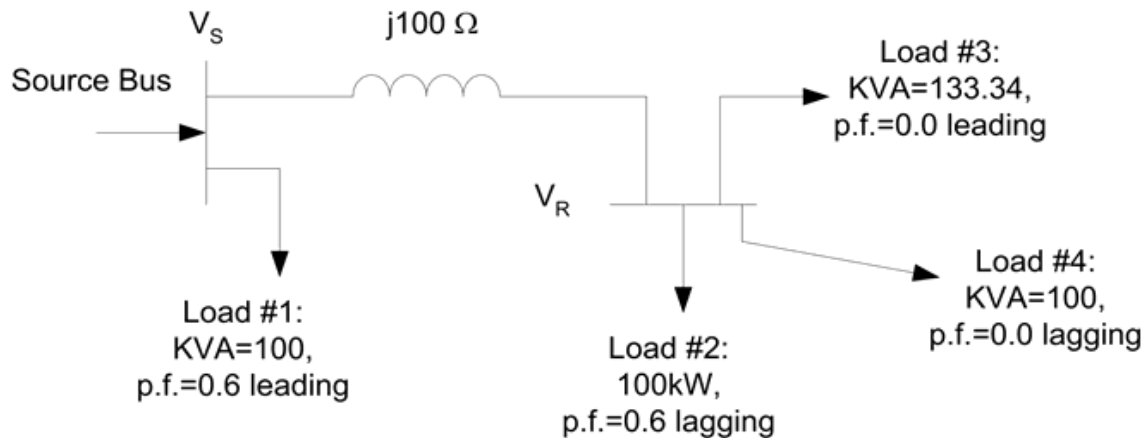

Compute the following:

- 1) The source voltage  $V_S$ , if  $V_R$  is to be maintained at 4.4 kV ( $V_R=4.4$  kV line value).
- 2) The source current and power supplied by the source.
- 3) The total complex power supplied by the source.
- 4) How much reactive power should be connected to the source bus for obtaining unity power factor at the source bus?