

Problem Set #2 Transformers and per unit value

2-1

A single-phase transformer rated 1.2kV/120V, 7.2kVA yields the following test results:

Open circuit test (primary-open)

Voltage $V_2 = 120\text{V}$; current $I_2 = 1.2\text{ A}$; power $W_2 = 40\text{ W}$

Short circuit test (secondary-shortcd)

Voltage $V_1 = 20\text{V}$; current $I_1 = 6.0\text{ A}$; power $W_1 = 36\text{ W}$

Determine

a) The parameters $R_1=r_1+a^2r_2$, $X_1=x_1+a^2x_2$, G_c , and B_m referred to the primary side, Fig. 1

b) The values of the above parameters referred to the secondary side.

c) The efficiency of the transformer when it delivers 6kVA at 120V and 0.9 power factor.

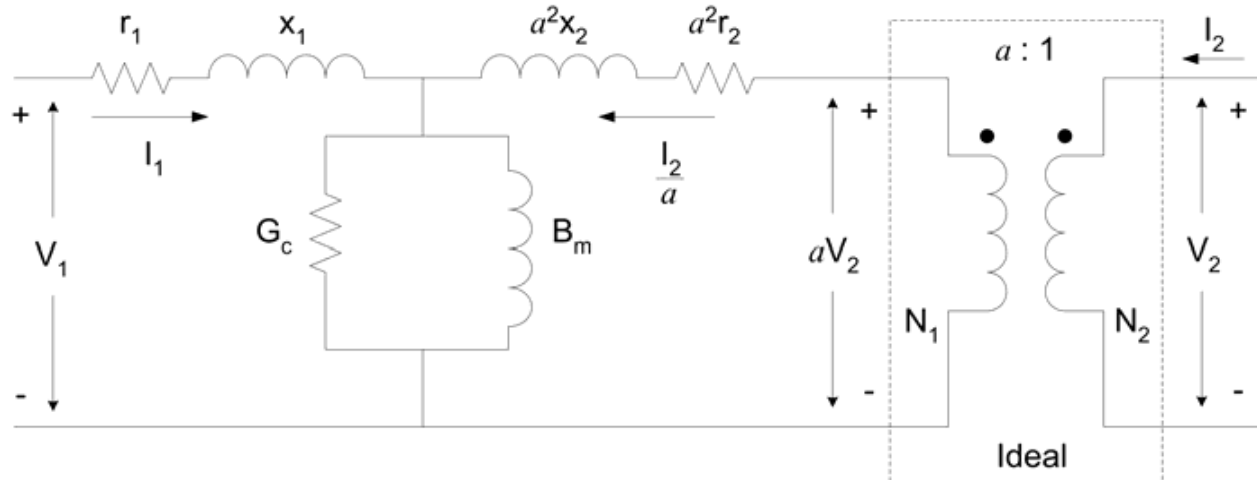

Fig. 1: Equivalent circuit for a single-phase transformer with an ideal transformer of turns ratio $a=N_1/N_2$.

2-2

A single-phase system similar to that shown in Fig. 2 has two transformers A-B and B-C connected by a line B feeding a load at the receiving end C. The ratings and parameter values of the components are:

Transformer A-B: 500V/1.5kV, 9.6kVA, leakage reactance = 5%

Transformer B-C: 1.2kV/120V, 7.2kVA, leakage reactance = 4%

Line B: series impedance = $(1.5+j3.0)\ \Omega$

Load C: 120V, 6kVA at 0.8 power-factor lagging

a) Determine the value of the load impedance in ohms and the actual ohmic impedances of the two transformers referred to both their primary and secondary sides.

b) Choosing 1.2 kV as the voltage base for circuit B and 10 kVA as the systemwide kVA base, express all system impedances in per unit.

c) What value of sending-end voltage corresponds to the given loading conditions?



Fig. 2: Circuit of two transformers connected in series.

2-3

A transformer rated 200 MVA, 345Y/20.5 Δ kV connects a balanced load rated 180 MVA, 22.5 kV, 0.8 power-factor lag to a transmission line. Determine

- The rating of each of three single-phase transformers which when properly connected will be equivalent to the above three-phase transformer.
- The complex impedance of the load in per unit in the impedance diagram if the base in the transmission line is 100 MVA, 345 kV.

2-4

A three-phase transformer rated 5 MVA, 115/13.2 kV has per-phase series impedance of $(0.007 + j0.075)$ per unit. The transformer is connected to a short distribution line which can be represented by a series impedance per phase of $(0.02 + j0.10)$ per unit on a base of 10 MVA, 13.2 kV. The line supplies a balanced three-phase load rated 4 MVA, 13.2 kV, with lagging power factor 0.85.

- Draw an equivalent circuit of the system indicating all impedances in per unit. Choose 10 MVA, 13.2 kVA as the base at the load.
- With the voltage at the primary side of the transformer held constant at 115 kV, the load at the receiving end of the line is disconnected. Find the voltage regulation at the load.

2-5

Three identical single-phase transformers, each rated 1.2kV/120V, 7.2kVA and having a leakage reactance of 0.05 per unit, are connected together to form a three-phase bank. A balanced Y-connected load of 5 Ω per phase is connected across the secondary of the bank. Determine the Y-equivalent per-phase impedance (in ohms and in per unit) seen from the primary side when the transformer bank is connected (a) Y-Y, (b) Y- Δ , (c) Δ -Y, (d) Δ - Δ . Use Table 2.1.

TABLE 2.1
Transferring ohmic values of per-phase impedances
from one side of a three-phase transformer to another†

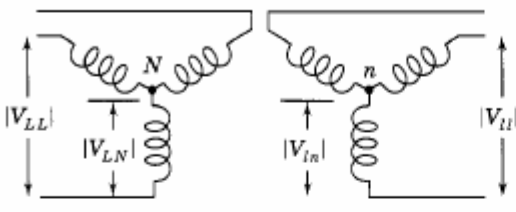
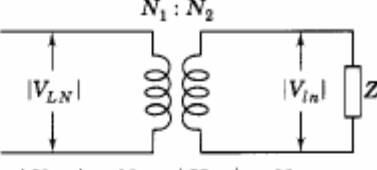
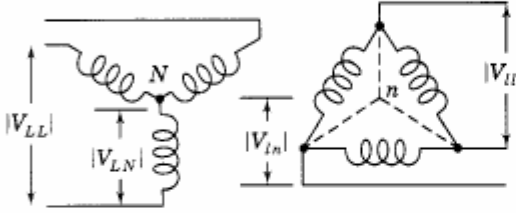
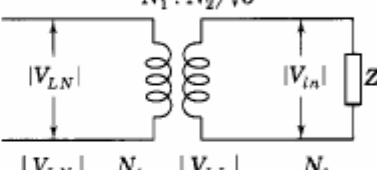
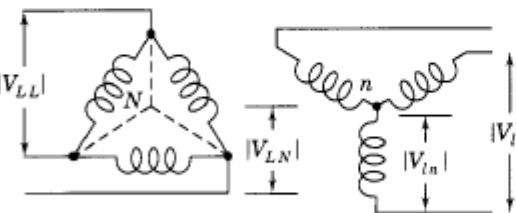
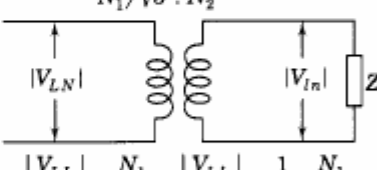
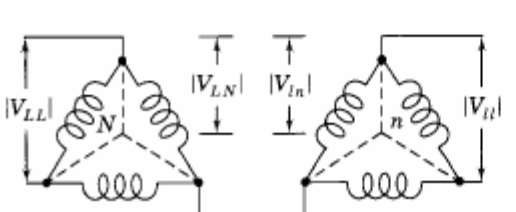
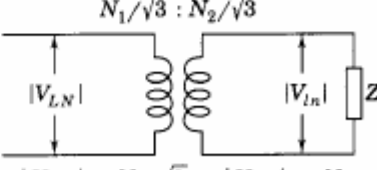
<p>Y-Y</p> 	<p>$N_1 : N_2$</p>  <p>$\left \frac{V_{LN}}{V_{in}} \right = \frac{N_1}{N_2} ; \left \frac{V_{LL}}{V_{ll}} \right = \frac{N_1}{N_2}$</p> <p>$Z_H = \left(\frac{N_1}{N_2} \right)^2 Z_L = \left \frac{V_{LL}}{V_{ll}} \right ^2 Z_L$</p>
<p>Y-Δ</p> 	<p>$N_1 : N_2/\sqrt{3}$</p>  <p>$\left \frac{V_{LN}}{V_{in}} \right = \frac{N_1}{N_2} ; \left \frac{V_{LL}}{V_{ll}} \right = \sqrt{3} \frac{N_1}{N_2}$</p> <p>$Z_H = \left(\frac{N_1}{N_2/\sqrt{3}} \right)^2 Z_L = \left \frac{V_{LL}}{V_{ll}} \right ^2 Z_L$</p>
<p>Δ-Y</p> 	<p>$N_1/\sqrt{3} : N_2$</p>  <p>$\left \frac{V_{LL}}{V_{in}} \right = \frac{N_1}{N_2} ; \left \frac{V_{LL}}{V_{ll}} \right = \frac{1}{\sqrt{3}} \frac{N_1}{N_2}$</p> <p>$Z_H = \left(\frac{N_1/\sqrt{3}}{N_2} \right)^2 Z_L = \left \frac{V_{LL}}{V_{ll}} \right ^2 Z_L$</p>
<p>Δ-Δ</p> 	<p>$N_1/\sqrt{3} : N_2/\sqrt{3}$</p>  <p>$\left \frac{V_{LN}}{V_{in}} \right = \frac{N_1/\sqrt{3}}{N_2/\sqrt{3}} ; \left \frac{V_{LL}}{V_{ll}} \right = \frac{N_1}{N_2}$</p> <p>$Z_H = \left(\frac{N_1/\sqrt{3}}{N_2/\sqrt{3}} \right)^2 Z_L = \left \frac{V_{LL}}{V_{ll}} \right ^2 Z_L$</p>

†Secondary load consists of balanced Y-connected impedances Z_L .

2-6 (Keyhani Lecture)

It is frequently necessary to change impedance data from one base to another. Prove that,

$$Z_{pu2} = Z_{pu1} \left[\frac{V_{b1}}{V_{b2}} \right]^2 \left[\frac{S_{3\phi b2}}{S_{3\phi b1}} \right]$$

where subscripts 1 and 2 represent different base sets.

2-7 (Keyhani Lecture)

A given impedance is 0.050 per-unit on bases of $V_b=138\text{kV}$ and $S_{3\phi b}=200\text{MVA}$.

Calculate Z in per-unit if base values for V_b and $S_{3\phi b}$ are, respectively,

- a) 138 kV, 100 MVA
- b) 132 kV, 200 MVA
- c) 132 kV, 100 MVA

2-8 (Keyhani Lecture)

A transformer bank is composed of three single-phase transformers supplying a three-phase load consisting of three identical 10Ω resistors. Each single-phase transformer is rated 10 MVA, 38.1-3.81 kV, with a leakage reactance of 10%. Resistance may be neglected. The load is connected to the low-voltage side of the bank. The first symbol in the designation of the transformer connection in column 1 of the table included as part of the problem indicates the connection of the high-tension side of the transformer bank. Fill in the blanks in the table for a base of 30 MVA. The impedance that would be marked on an impedance diagram is either the ohmic or the per-unit value of the impedance of one phase of the Y-connected equivalent circuit.

Transformer Connection (1)	Load Connection (2)	Line-to-line base, kV		Base Z, Ω		Z viewed from HT, Ω (7)	Z of load, per unit (8)	Z viewed from HT, per unit (9)
		LT (3)	HT (4)	LT (5)	HT (6)			
1) Y-Y	Y	6.6						
2) Y-Y	Δ	6.6						
3) Y- Δ	Y	3.81						
4) Y- Δ	Δ	3.81						
5) Δ -Y	Y	6.6						
6) Δ -Y	Δ	6.6						

NOTE: Column 7 refers to the impedance in ohms of the transformer plus the load viewed from the high tension side of the transformer. Column 8 refers to the per-unit impedance of the load computed on the base for the load circuit. Column 9 refers to the impedance of the transformer and load viewed from the high-tension side of the transformer expressed in per unit on the base for the high-tension circuit.